

DETAIL A
SCALE 1:2

Nota:
La soldadura es igual para todos los soportes

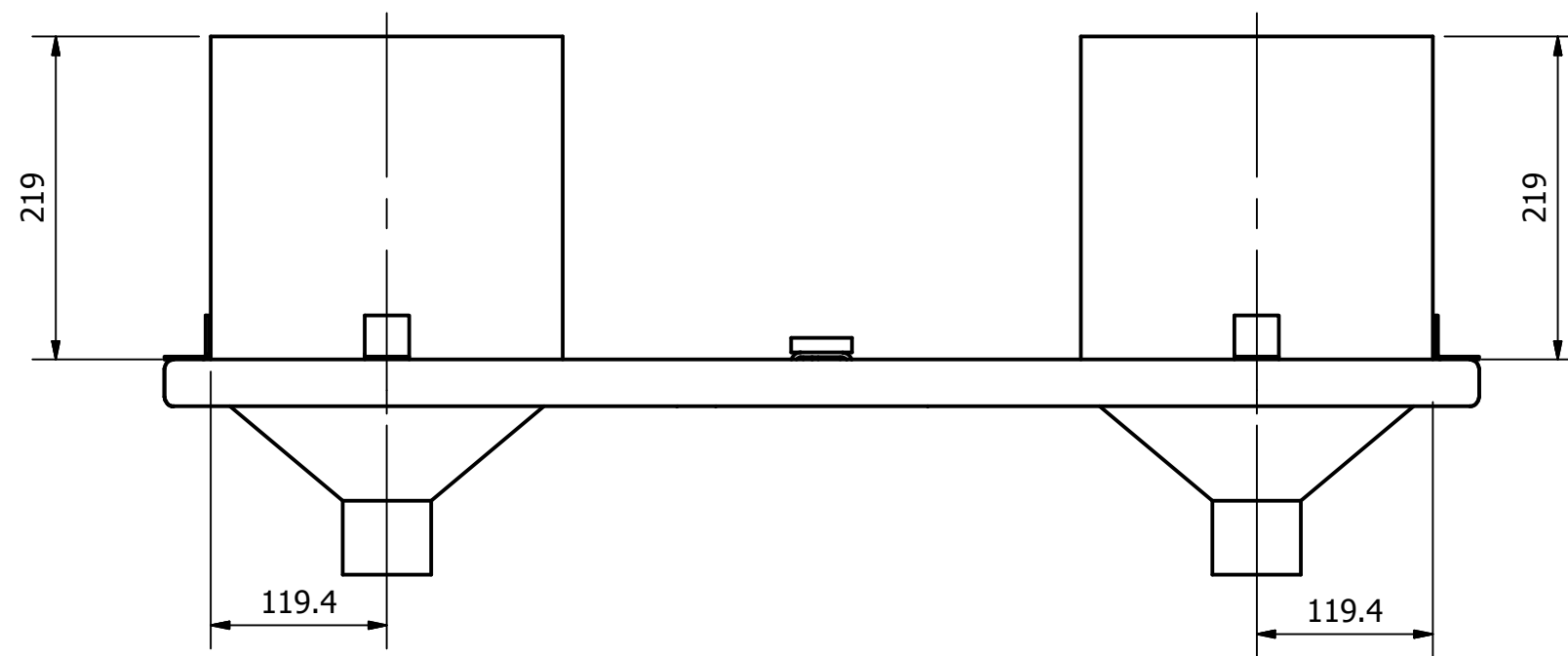

	FUNDACIÓN UNIVERSIDAD DE AMÉRICA			Elaboró: Juan Pablo Barrera Barragán
	FACULTAD DE INGENIERÍA MECÁNICA			
PROYECTO: MÁQUINA AUTOMATIZADA PARA PRODUCCIÓN DE EMPANADAS				
	PLANO 1.03.10	FECHA: 22/04/2017	ESCALA 1:5	Nombre Pieza: Detalle soldadura soporte tolvas
	Hoja 27 de 42			