

Detalle anclaje al suelo

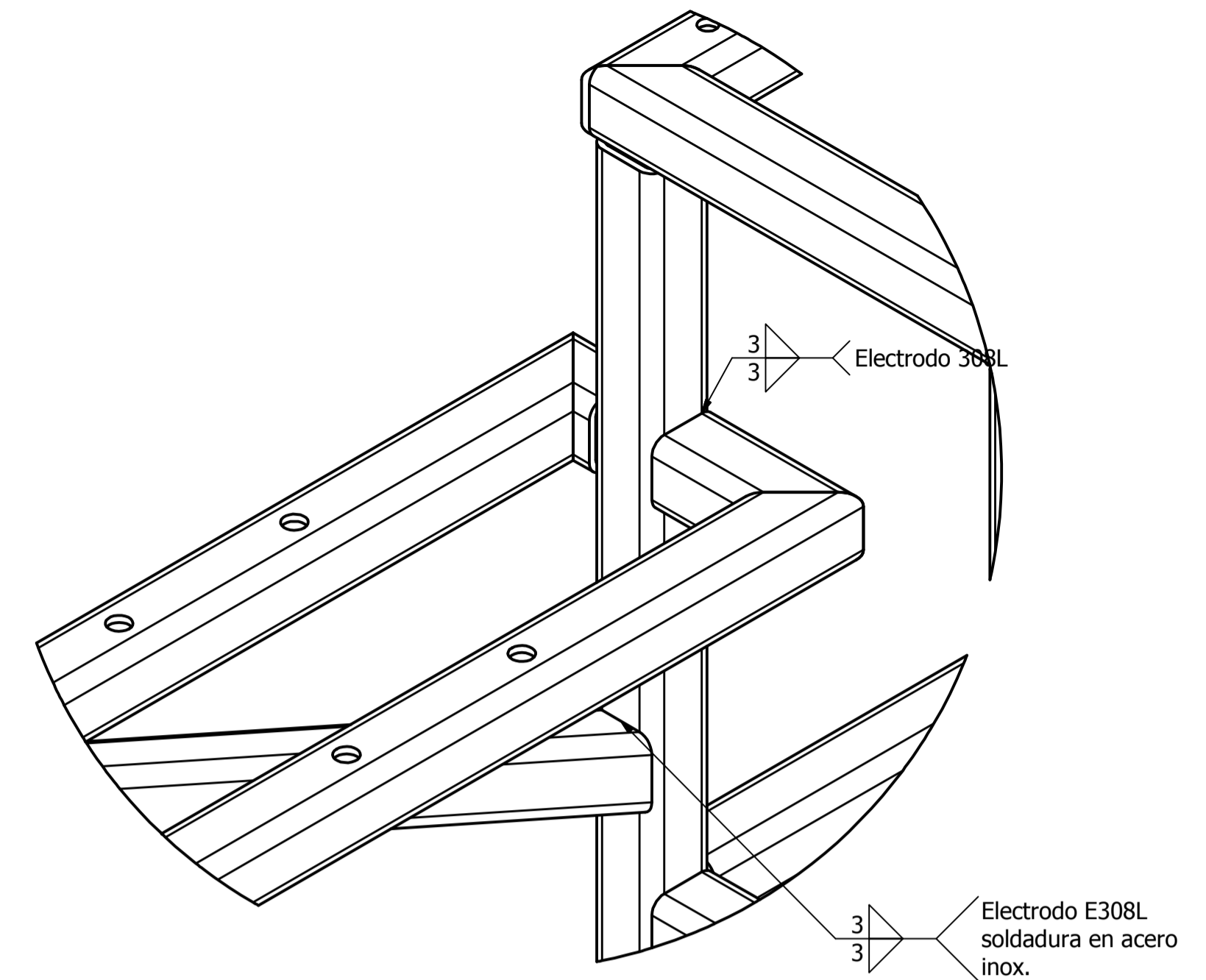

DETAIL A  
SCALE 1:2

