

HOLE TABLE			
HOLE	XDIM	YDIM	DESCRIPTION
A1	50.00	9.50	Ø8.00
B1	9.50	119.79	Ø8.00
B2	9.50	189.79	Ø8.00
B3	145.00	9.50	Ø8.00
B4	240.00	9.50	Ø8.00
B5	280.50	49.79	Ø8.00
B6	280.50	119.79	Ø8.00
B7	280.50	189.79	Ø8.00
C1	86.85	144.59	Ø21.00
D1	203.15	144.59	Ø32.00

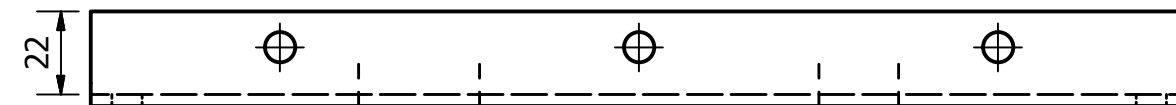
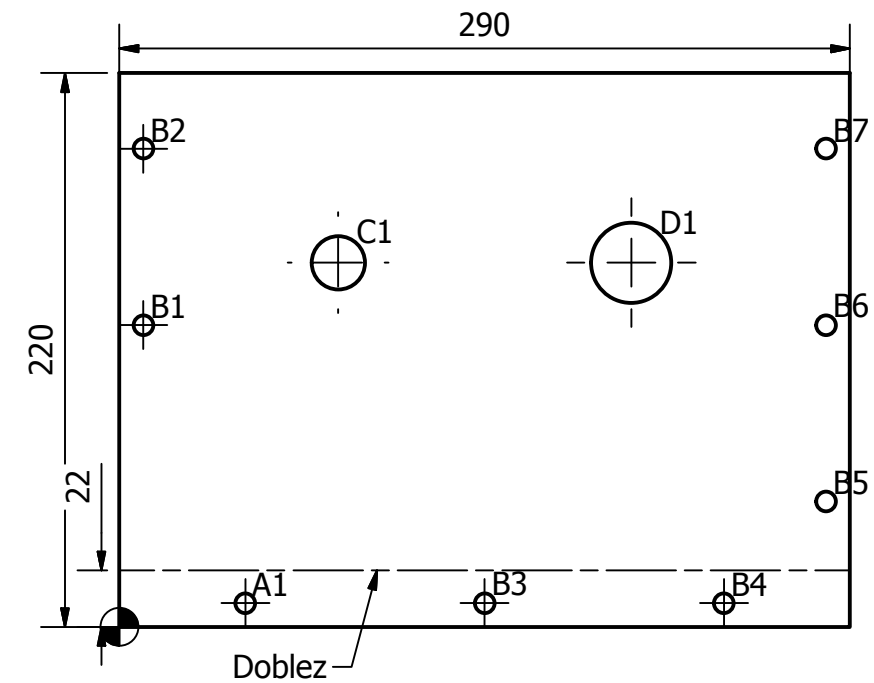
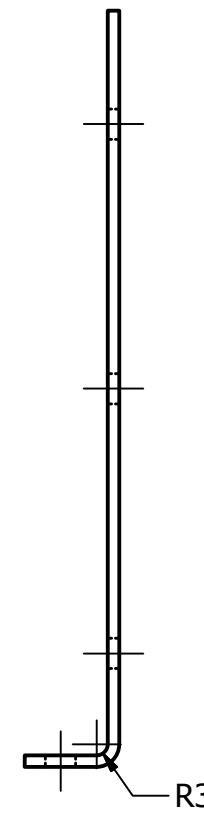
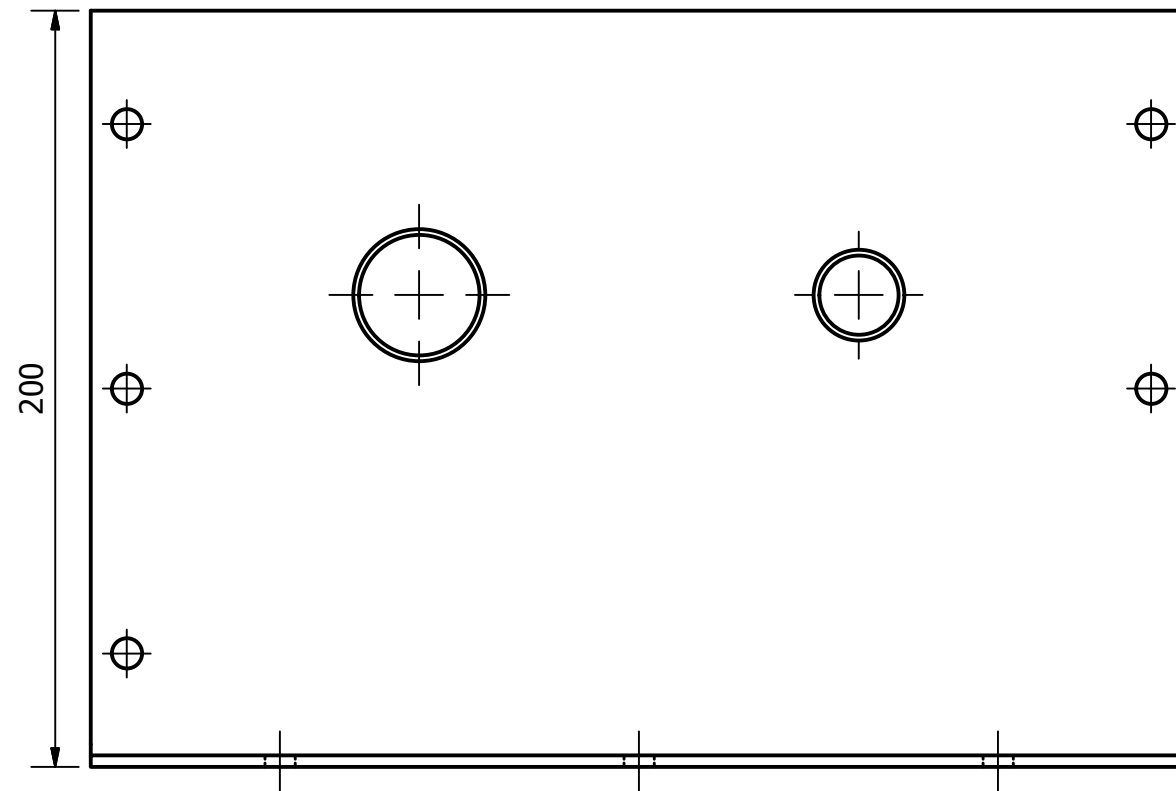

5	2	Placa Lateral	Acero inox. 304, espesor 3 mm
ITEM	QTY	PART NUMBER	MATERIAL
 FUNDACIÓN UNIVERSIDAD DE AMÉRICA FACULTAD DE INGENIERÍA MECÁNICA			
PROYECTO: MÁQUINA AUTOMATIZADA PARA PRODUCCIÓN DE EMPANADAS			
	PLANO 1.01.02	FECHA: 22/04/2017	ESCALA 1:5
	Hoja 4 de 42	Elaboró: Juan Pablo Barrera Barragán	
			Nombre plano: Placa lateral