

RevNo	Revision note	Date	Signature	Requested by
1	First Issue on CAD		B.A Mills	

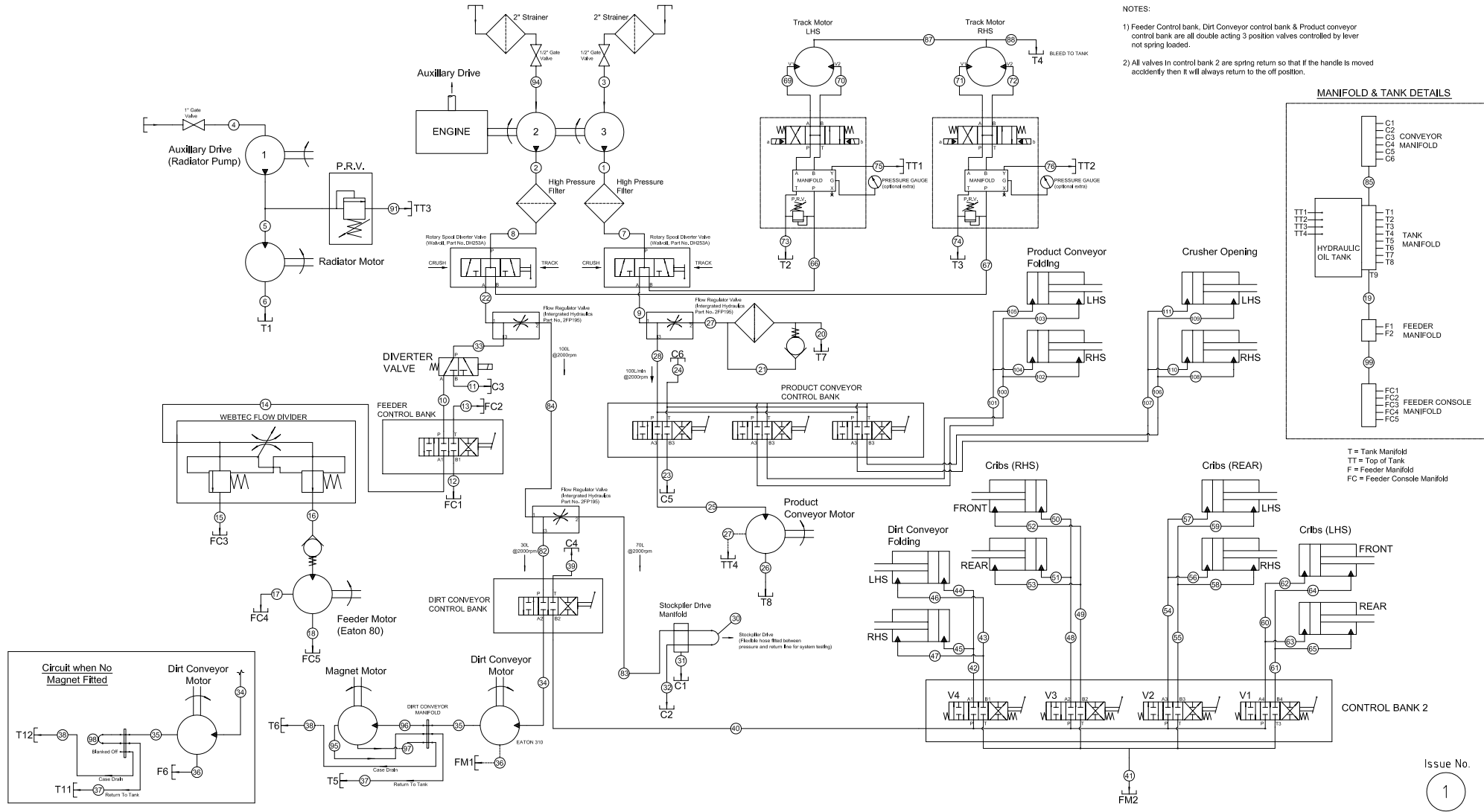

NOTES:
 1) Feeder Control bank, Dirt Conveyor control bank & Product conveyor control bank are all double acting 3 position valves controlled by lever not spring loaded.
 2) All valves in control bank 2 are spring return so that if the handle is moved accidentally then it will always return to the off position.

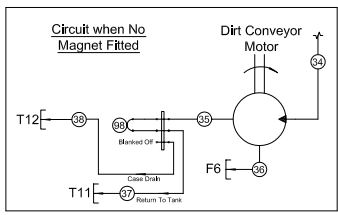
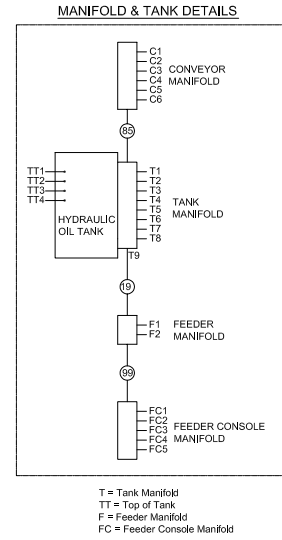

Issue No.
 1

DO NOT SCALE - ASK IF IN DOUBT
 NO ALTERATIONS TO BE MADE WITHOUT TESAB D.O. AUTHORISATION

TITLE: RK 1012T ROTOCRUSHER
 Fast Track Hydraulic Diagram
 TESAB Engineering Ltd.

DRN BY: B.A Mills
 DATE: 19.09.02
 DR. NO. 1012FTHYDDIA.001