

Item Number	File Name	Quantity	MATERIAL/REFERENCIA
1	Viga	1	ASTM A500
2	Base Pared	1	ACERO A 36
3	Angulo	1	ACERO A 36
4	Angulo 2	2	ACERO A 36
5	Angulo 3	1	ACERO A 36
6	Base Lateral	2	ACERO A 36
7	RODILLOS BASE ESTIBA	2	A 1020

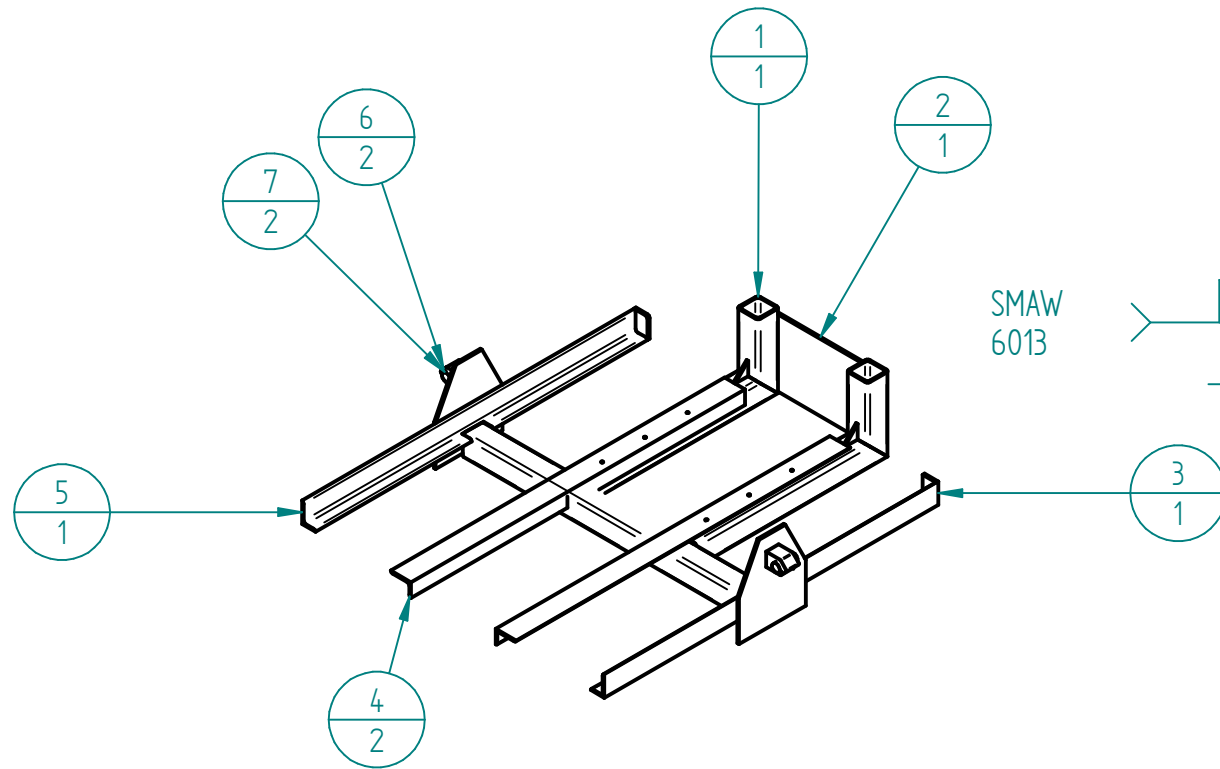
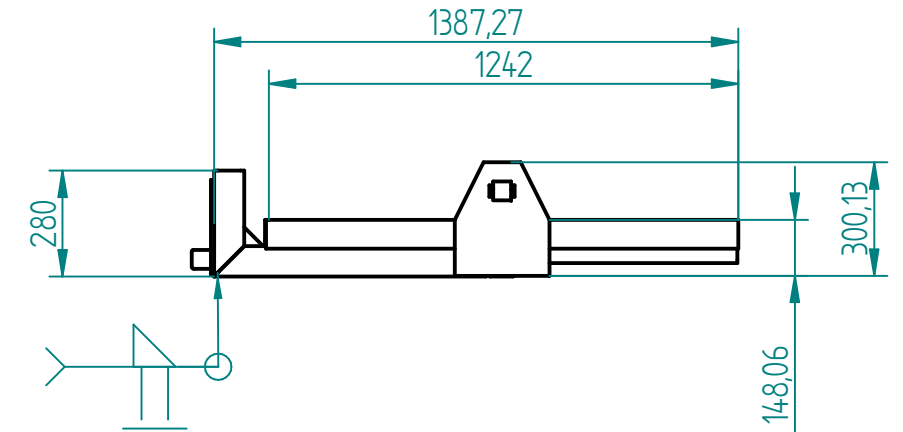
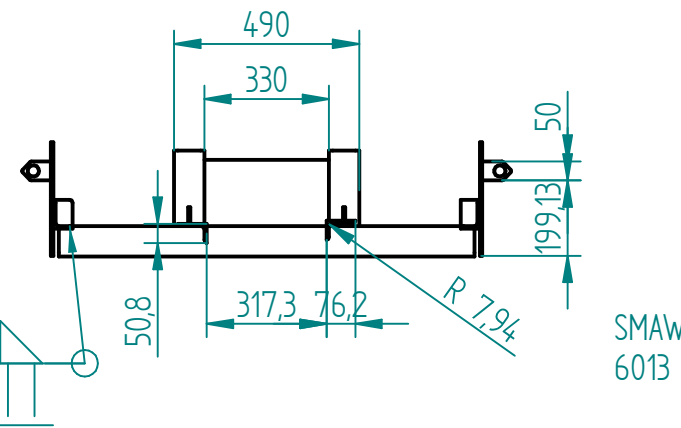
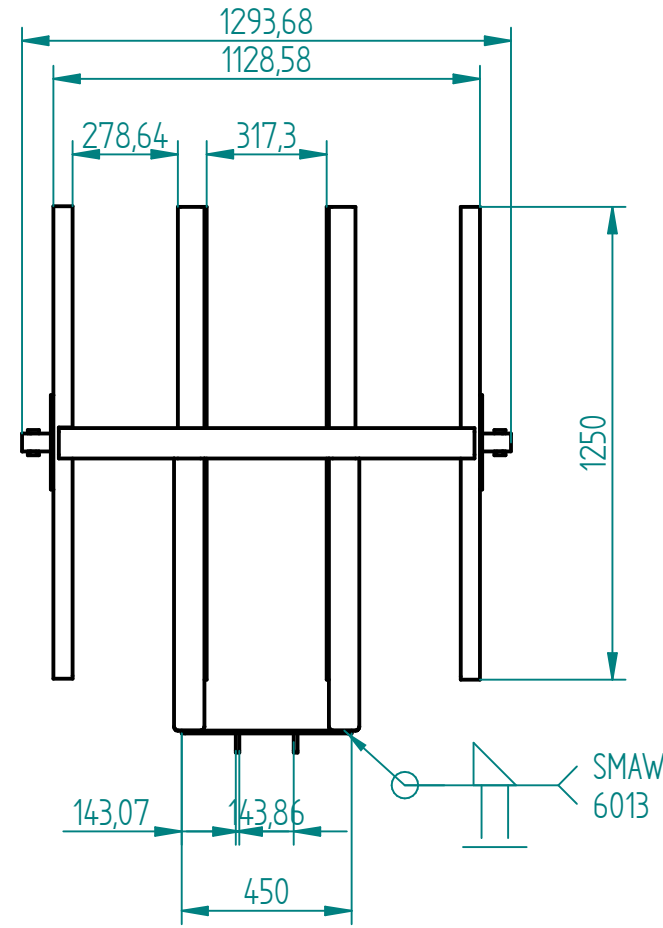

DRAWN	J.BRAND	Fundación Universidad de América	
CHECKED	L.ORTEGA	TITLE	
SI NO SE INDICA LO CONTRARIO: LAS COTAS SE EXPRESAN EN mm		CARRO ESTIBA	
ACABADO SUPERFICIAL:		SIZE	DWG NO
TOLERANCIAS:		A3	4.2.1.
LINEAL: 3cm		FILE NAME: CARRO ESTIBAS 4.2.1.dft	
ANGULAR: 1°X		SCALE: 1:20	COD: SAC421

SOLID EDGE ACADEMIC COPY