

Item Number	File Name	Quantity	MATERIAL/REFERENCIA
1	LTR 2	2	ASTM A500 G C
2	LTR 1	2	ASTM A500 G C
3	ESTR 1	4	ASTM A500 G C
4	ESTR 2	2	ASTM A500 G C
5	ESTR 3	2	ASTM A500 G C
6	L3	1	ASTM A500 G C
7	SFT1	1	ASTM A500 G C

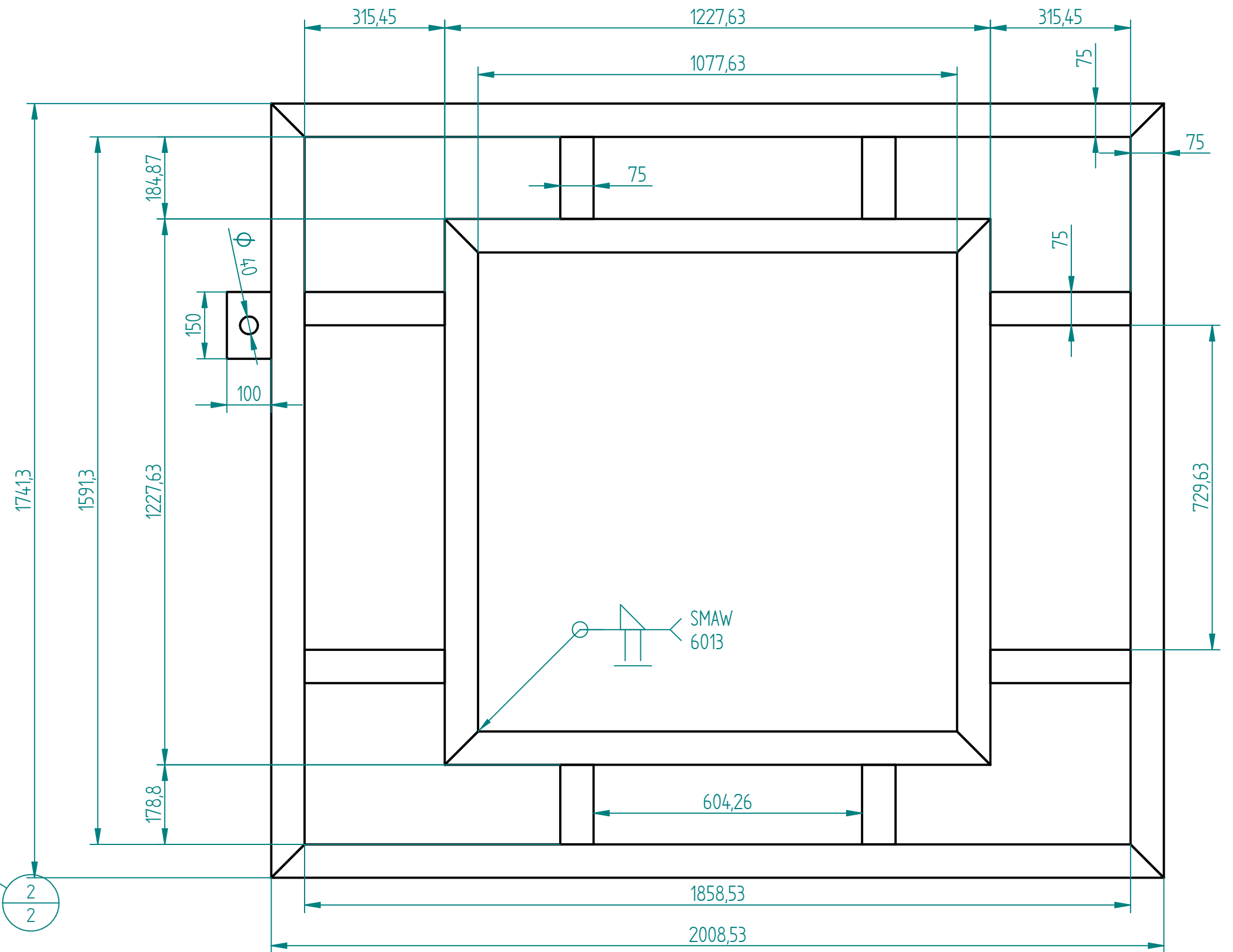
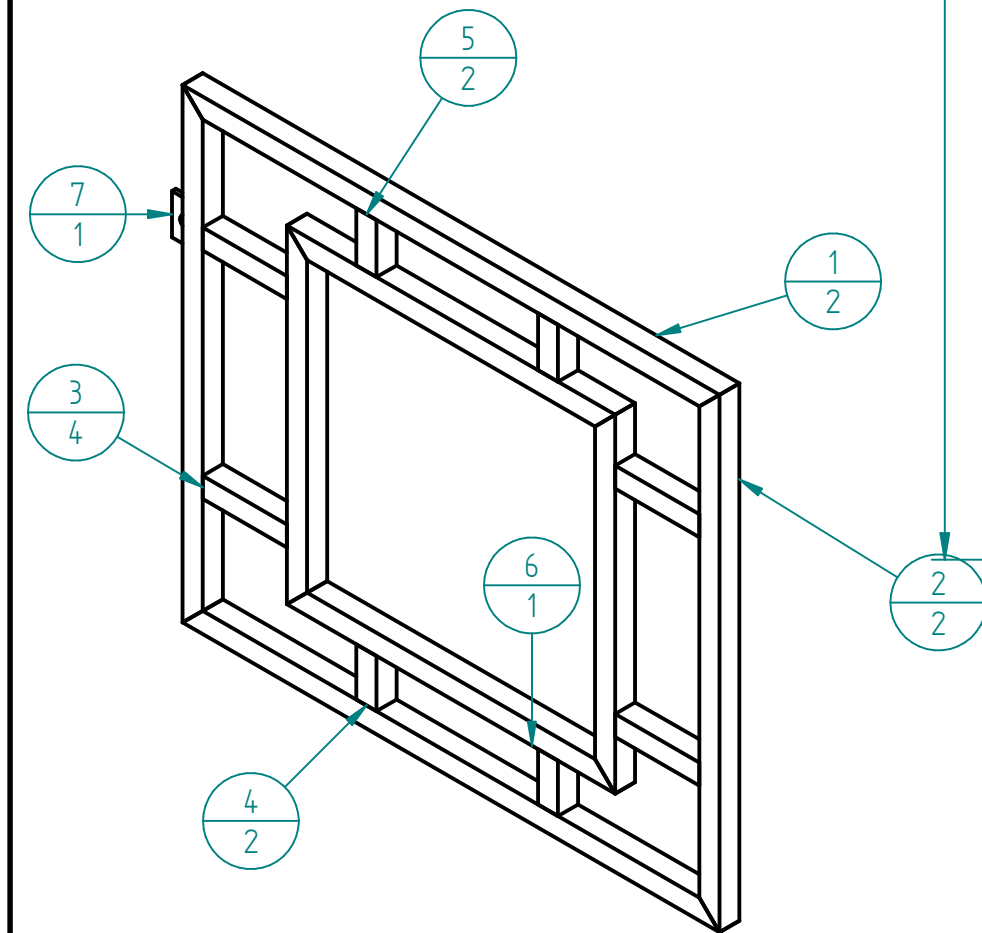

DRAWN	J.BRAND	Fundación Universidad de América
CHECKED	L.ORTEGA	
SI NO SE INDICA LO CONTRARIO: LAS COTAS SE EXPRESAN EN mm		TITLE ESTRUCTURA BASE SUPERIOR
ACABADO SUPERFICIAL: TOLERANCIAS: LINEAL: 3cm ANGULAR: 1°X. TODOS LOS PERFILES DE ESTA ESTRUCTURA VAN SOLDADO CON SMAW 6013		SIZE DWG NO A3 4.31
		FILE NAME: ESTRUCTURA BASE SUPERIOR 4.3.1.dft
		SCALE: 1:10 COD: SAC431

SOLID EDGE ACADEMIC COPY